

CREST 2807 SLOTTED TOE RAIL



Crest Aluminum Products Inc
Part No. C-2807
Slotted Toe Rail

MARINE PRODUCTS
www.crestaluminum.com

SIDE VIEW

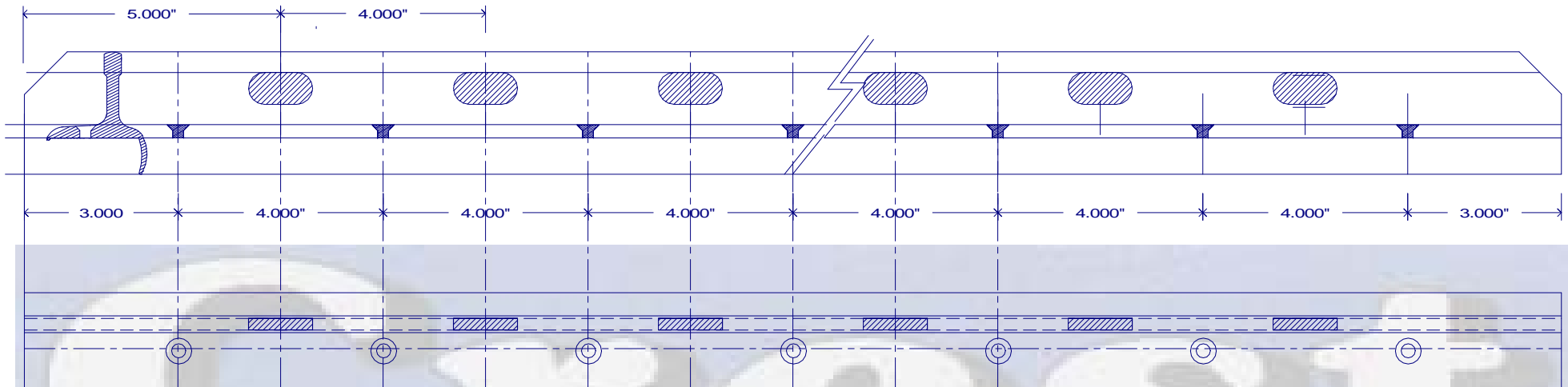

TOP VIEW

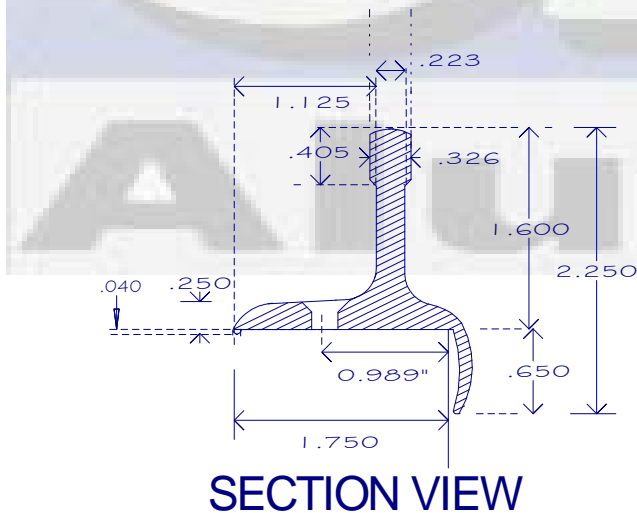

SECTION VIEW

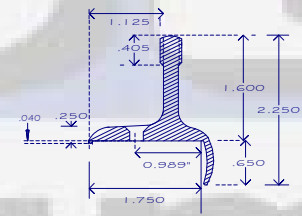

SECTION VIEW

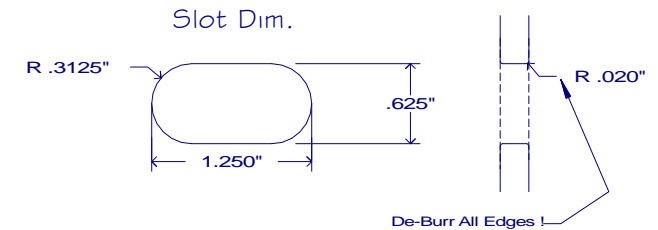
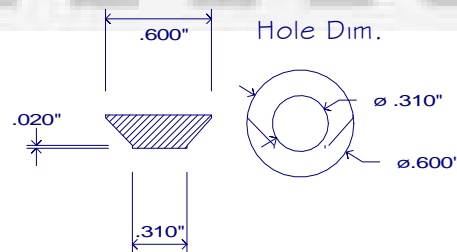

Notes:

Alloy: 6061 T-6
Finish: Hard Coat Anod.
30 Min Clr. Velo
Lengths: 24'-0"
Slots: 3 1/2" On Center
Wt./ Ft.: .959 lbs.

PART NO.	C-2807		Crest Aluminum Products Inc 8287 Tyler Blvd Mentor OH 44060 USA	REVISIONS	DATE
ALLOY	6061 T-6				
FINISH	BLK HDCT ANOD 30 MIN CLR VELO	JOB NO.	DATE: 11/21/06		
LENGTHS	24'-0"	CUSTOMER / PROJECT CTP 2807			
UNSPEC RADIUS	.016"	© Crest Aluminum Products Inc 2006 J.M. Allin			
DRAWING BY:	J. M. ALLIN				